

R. W. AITKEN.
Piston-Valve for Engines.

No. 204,649.

Patented June 11, 1878.

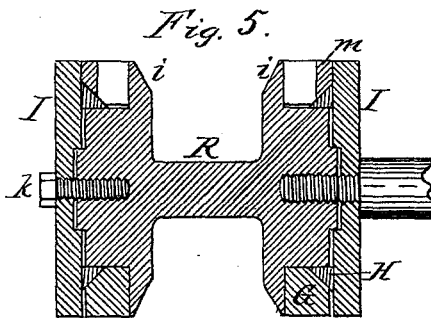
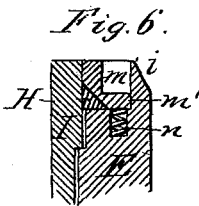
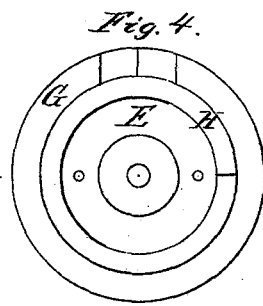
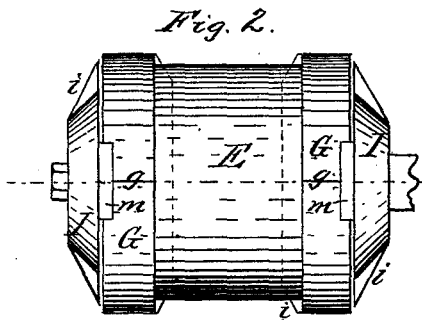
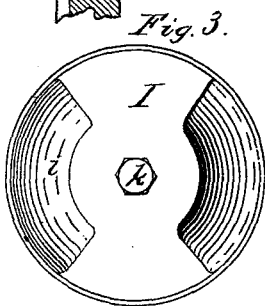
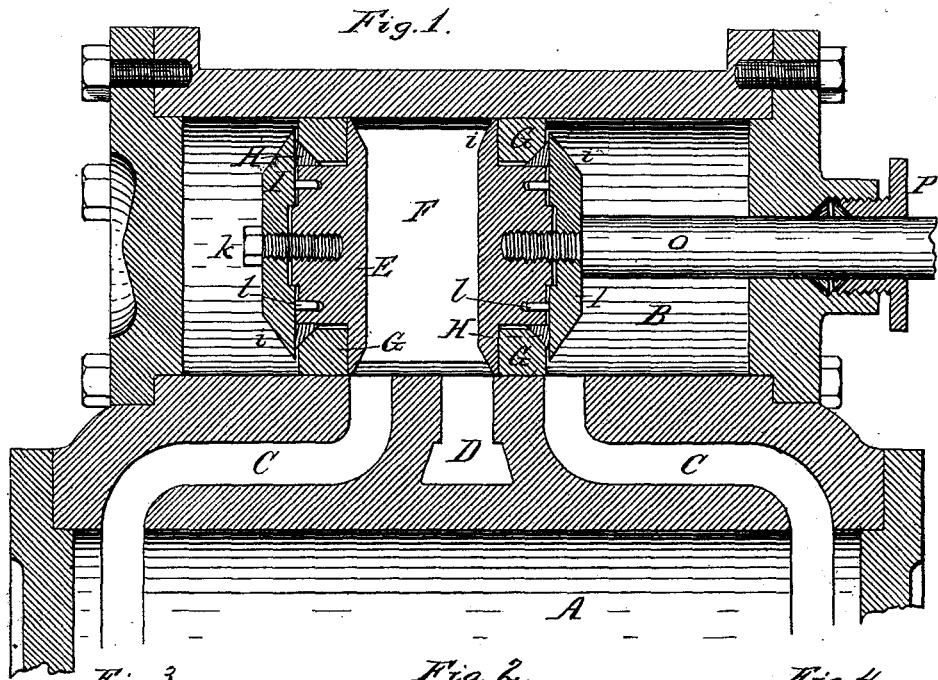

Witnesses:

Chas. J. Buchheit.....
Ernest H. Adcock.....

Inventor - Robert W. Aitken.....
By - Wilhelm Horned.....
Attorneys.....

UNITED STATES PATENT OFFICE.

ROBERT W. AITKEN, OF BUFFALO, NEW YORK.

IMPROVEMENT IN PISTON-VALVES FOR ENGINES.

Specification forming part of Letters Patent No. 204,649, dated June 11, 1878; application filed April 29, 1878.

To all whom it may concern:

Be it known that I, ROBERT W. AITKEN, of the city of Buffalo, in the county of Erie and State of New York, have invented new and useful Improvements in Piston-Valves for Steam-Engines, of which the following is a specification, reference being had to the accompanying drawing.

My invention relates to a piston-valve which is perfectly balanced, so as to require very little power for operating and reversing it, and which is at the same time steam-tight, and simple and durable in construction.

My invention consists of the particular construction of the device, as will be hereinafter fully set forth.

In the accompanying drawing, Figure 1 is a horizontal section through the valve and valve-chest. Fig. 2 is a top-plan view of the valve. Fig. 3 is an end view thereof. Fig. 4 is an end view with the cover removed. Fig. 5 is a sectional view, showing a modified form of the valve. Fig. 6 is a fragmentary sectional view of one of the packing-rings, showing a modification of the means for covering the slot of the ring.

Like letters of reference refer to like parts in each of the figures.

A represents the steam-cylinder; B, the valve-chest; C C, the steam-ports, and D the exhaust-port. The valve-chest B is made of cylindrical form, concentric with the valve-stem, in the usual manner. E is the body of the piston-valve, provided with a central exhaust-cavity, F. G G represent the split packing-rings, arranged in annular recesses of the valve-body E, so as to bear with their inner side against the valve-body while their outer side is exposed. The packing-rings G G are made slightly larger than the bore of the valve-chest, so that when compressed in order to enter the valve-chest they will possess sufficient elasticity to retain their circumference in steam-tight contact with the valve-chest. H is a beveled split packing-ring, bearing against the beveled seat with which each main packing-ring G is provided, and held to its seat by a cover or follower, I, which is secured to the body of the valve by a screw-bolt, k, or in any other suitable manner. The covers I are beveled on the side opposite the steam-ports and the body

E of the valve adjacent to the exhaust-cavity, as shown at *i*, so as to permit the free entrance and escape of the steam into and from the ports. The covers I are prevented from turning by pins or studs *l*, secured to the covers and projecting into corresponding openings in the body of the valve. *m* is a packing block or plate, placed against the outer side of the slit *g* of each main packing-ring G, which latter is provided with a recess for the reception of the plate *m*. The inner end of the plate is beveled to correspond with the bevel of the split ring H, which bears against the inner end of the plate, and holds it tightly against the slit of the main packing-ring and against the inner side of the valve-chest. If desired, the plates *m* may be provided with an extension, *m'*, extending under the slit *g* of the main packing-ring G, between the latter and the body of the valve, when the plate *m* is held in contact with the main packing-ring by a spiral spring, *n*, arranged in a socket in the valve-body, as shown in Fig. 6. *o* is the valve-stem, screwed into or otherwise secured to the body E of the valve, and guided in a stuffing-box, P, in the usual manner.

The steam enters the valve-chest at each end by means of a bifurcated pipe or passage connecting with the steam-supply pipe, and after having passed through the cylinder the steam escapes through the exhaust-cavity F of the valve into the exhaust-port. The steam-pressure upon both ends of the valve is perfectly balanced, thereby leaving the valve free to be moved in the valve-chest by simply overcoming the friction of the packing-rings against the interior of the valve-chest. The pressure of the covers I upon the beveled rings H tends to expand the main packing-rings G, keeping the same in close contact with the interior of the valve-chest, and at the same time forms a steam-tight joint, which prevents the steam from exerting any pressure upon the inner surface of the main packing-rings. The natural elasticity of the beveled packing-rings H enables the same to follow the expansion of the main packing-rings within certain limits, and when this limit has been exceeded the covers I are tightened again. The packing-rings G are made somewhat wider than the steam-ports, to prevent the same from expanding

into the ports and injuring the latter or becoming injured thereby, which happens frequently when the packing-rings are narrower than the ports.

The principal parts of my improved valve can be turned and finished on the lathe, thereby rendering the valve cheap and capable of being easily repaired.

If preferred, the body of the valve may be constructed with an axial shank, R, forming an exhaust-cavity all around the shank, as shown in Fig. 5.

I claim as my invention—

1. A balanced piston-valve composed of the body E, provided with exhaust-cavity F, split main packing-rings G G, provided with beveled seats on their outer side, beveled split packing-rings H, and covers or followers I, arranged and operating as shown and described.

2. In a piston-valve, the combination, with the body E, of the recessed packing-rings G, provided with beveled seats, beveled split packing-rings H, packing-blocks *m*, and covers or followers I, substantially as and for the purpose set forth.

3. In a piston-valve, the combination, with the body E, of the packing-rings G, provided with beveled seats, beveled packing-rings H, and covers I, beveled opposite the steam-ports, and prevented from turning on the body of the valve, substantially as and for purpose set forth.

ROBERT W. AITKEN.

Witnesses:

JNO. J. BONNER,
CHAS. J. BUCHHEIT.